

Early

Deseret News



CONNECT

1 2 3



Your Family • Community • World

My name: _____

FROM THE DESK OF
WOODWORD

Dear readers—
November is Thanksgiving! I am very thankful for YOU and all of our Connect123 readers. Kids read us, teachers read us, parents read us, even grandparents read us!

Who do you read Connect with?
Be sure to share the fun of reading with someone in your family this month. There is a whole article on ways to celebrate Thanksgiving with others in your family. It's called Thanksgiving Together.

November is also a month to remember our Veterans. Be sure to take a look at Page 2 to learn about Operation Gratitude. This organization helps people show their gratitude to a Veteran and/or others that serve our communities.

Hand-written and drawn thank you notes are treasures. Take a few minutes this month to thank the people who make a difference in your life. Your gesture of gratitude will be a gift of joy to the people you send them to.

Thank YOU!

Woodword

THANKSGIVING TOGETHER

Thanksgiving is about Pilgrims, people and history — and turkey! But the best part about Thanksgiving is getting together with family and friends. Read more about it inside!



How many pumpkins can you count on this page in 60 seconds?

Thanksgiving Together



Sure, Thanksgiving is about Pilgrims and history – and turkey, of course! But the best part about Thanksgiving is getting together with family and friends and remembering all the things for which we are thankful. This page is for *everyone* in the family and features activities you can all do together!

Make Thanksgiving dinner place cards

Stuff You'll Need:

- Manila file folders (one per person)
- newspaper
- scissors
- glue stick



1. Cut off the folded end of a file folder to make a strip about 3-4 inches deep. Make one for each person coming to Thanksgiving dinner.

2. Cut out the letters from the newspaper that spell each person's name. Glue them onto one side of the place card.



3. Decorate the place cards with pictures from the newspaper.



Standards link: Reading comprehension: Follow simple, multiple-step written instructions.

Turkey trails

Start at the beginning of Trail A. Have a family member or friend start at Trail B. Who can reach the finish line first?

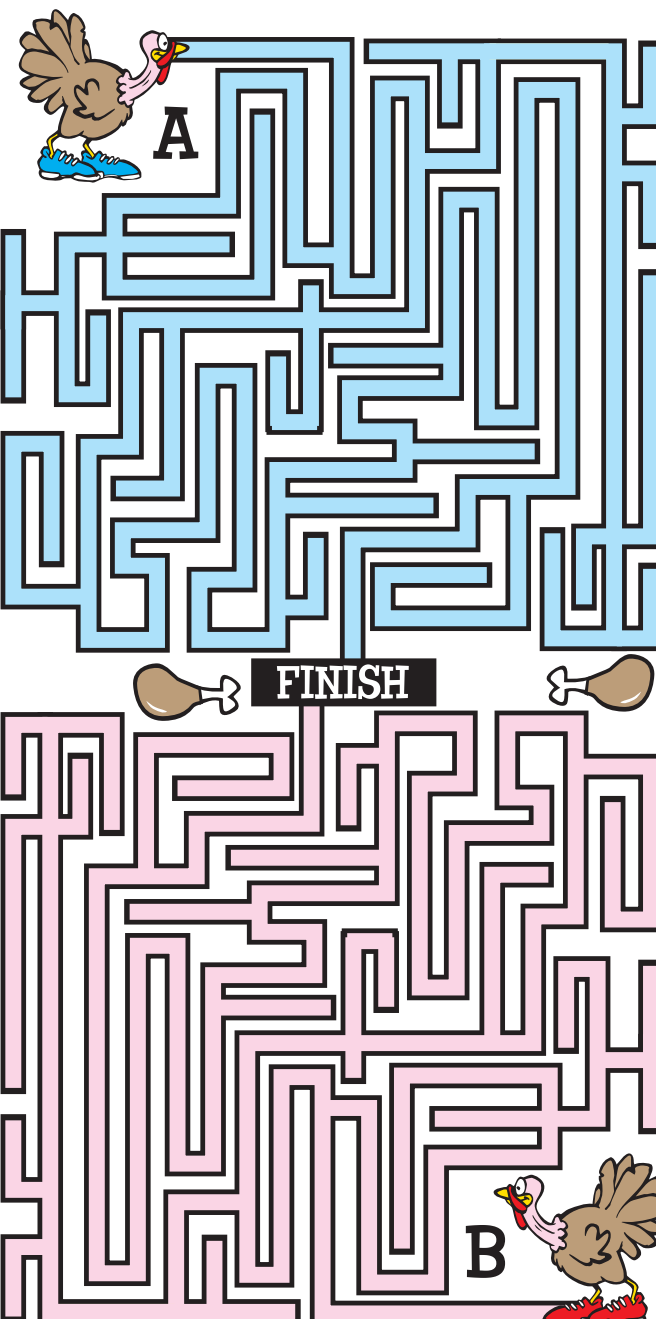

Zany turkey day tale

Pass the giggles! Ask a family member to give you seven nouns, one plural noun, one verb and one adjective. Then, fill in the blanks and read the story aloud.

Let the laughter begin! 

One Thanksgiving, we invited a _____ to the big feast. It was a huge mistake.

NOUN

Our guest had horrible _____ manners, and enjoyed smearing _____ in people's hair. Our guest then decided to _____ around Uncle Lou and cover Aunt Madge with

NOUN

NOUN

VERB

 _____

PLURAL NOUN

Later, our delicious _____ pie ended up in our _____

NOUN

ADJECTIVE

NOUN

This year, we invited a _____ . Hopefully, our new recipe for _____ stuffing is a success!

NOUN

NOUN

Standards link: Grammar: Identify and use nouns, adjectives and verbs in writing.

OPERATION GRATITUDE

In the month of November, we celebrate Veterans Day and Thanksgiving. A non-profit organization called **Operation Gratitude** lets you celebrate both at the same time by thanking the people who keep us safe.



"I would like to thank this group for the care package sent. Reading the comics was something that took me back to a normal routine of home. This was very much appreciated."

- J.G.

"I truly appreciate the love and concern that you've shown myself and my unit. Thank you very much for the care package."

- A.F.



"I really appreciate the effort you put into making sure that a soldier like myself feels appreciated while doing this job. Sometimes it becomes hard to remember why I chose this profession but when I hear from people like yourself and the others that wrote it makes it a little clearer. So once again thank you."

- TSgt. C.

Thanking Those Who Protect Us

Operation Gratitude collects thank you letters, cards, handmade gifts, snacks, pictures and more and sends them to:

- U.S. Troops
- First Responders
- Military Veterans
- Military Families
- Wounded Heroes & their Care Givers

The gifts and notes are boxed into care packages and sent to the people who bravely serve our country and communities. You and your family can take part in this special way to show thanks.

How to Send a Letter

Below are some of the Operation Gratitude guidelines for letters of appreciation. Visit www.operationgratitude.com for more information on the letters and where to send them.

- ★ Express your thanks for their selfless service.
- ★ Share a little about yourself: family, hobbies, work, school, pets, travel, etc.
- ★ Children's letters: Include first names only and do not include addresses.
- ★ Can't find the words? Consider artwork instead.
- ★ No glitter or confetti please!



FAMILY TIME

Thanksgiving is a time to talk!

After you eat some of your Thanksgiving meal, take a break from feasting to find out about the older people at the table. Snoop into the past of one or more by asking “When you were my age ...”

Write the responses on a separate piece of paper.

Standards link: Speaking comprehension: Ask for clarification of stories and ideas.

1. What did you eat on Thanksgiving, and who did the cooking?
2. How did you celebrate Thanksgiving?
3. What were you thankful for?
4. Did you have a pet?
5. What were your hobbies?
6. Did you watch television? What was your favorite show?
7. What chores did you do around the house?
8. How did you get spending money?
9. What did you like to spend it on?
10. What was your favorite story your grandparents told you?

ANSWERS

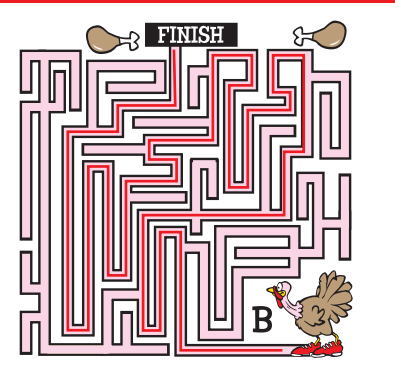

How to draw a TURKEY

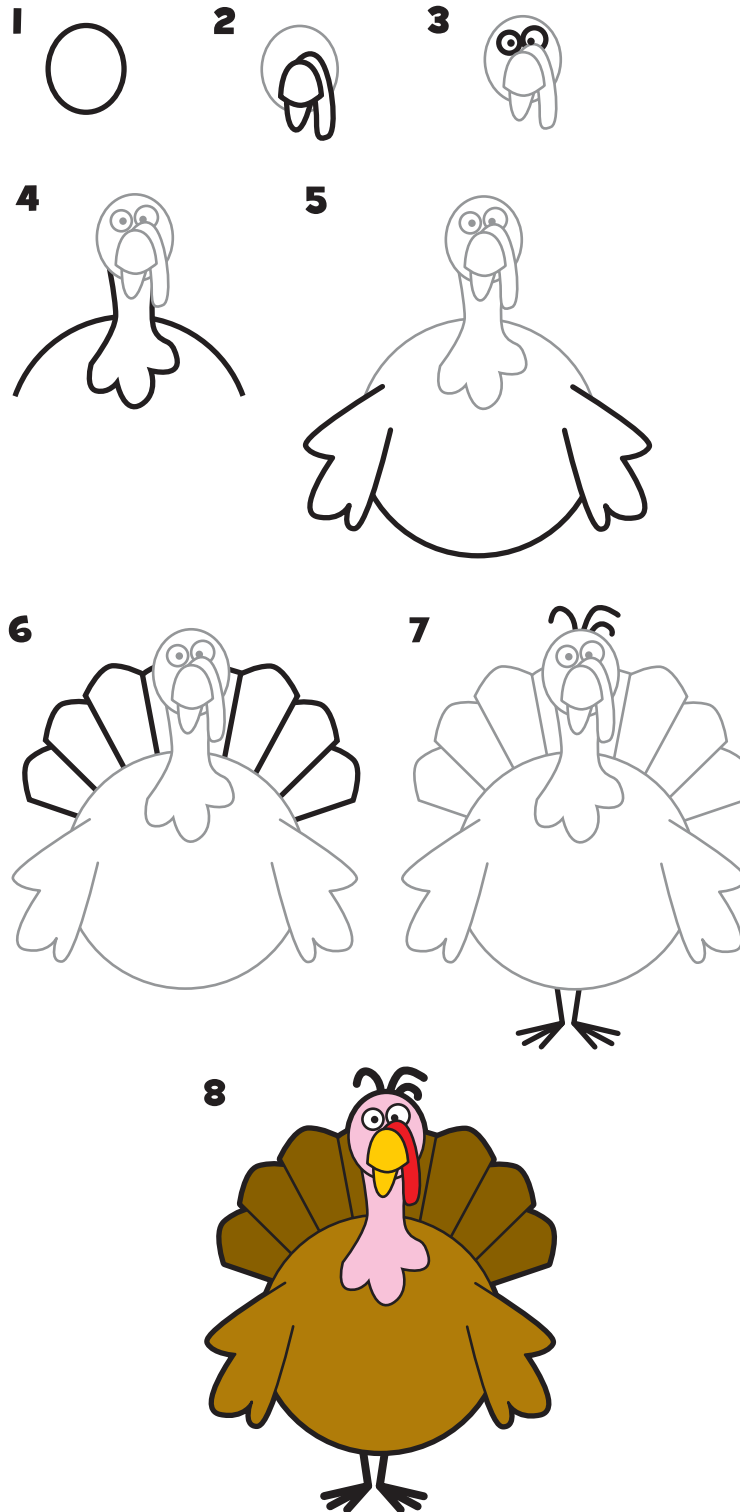

Learning buddy sign here

I have completed _____ activities with my learning buddy.

Learning buddy's signature _____ Date _____

Please send ideas, suggestions or information to: nie@deseretnews.com

If you would like to receive FREE copies of Connect 1•2•3 for your classroom, order on the Web at deseretnews.com/nie. Connect 1•2•3 is a FREE monthly educational section available only to schools through the Deseret News.

Content created for the Deseret News by: Kid Scoop. Educational fun for kids ages 4-11. www.kidscoop.com

NIE director: Cindy Richards crichards@deseretnews.com 55 N. 300 West Salt Lake City, UT 84101 801-237-2172



Read the book, watch the movie – or do both

What would you rather, read



the book or see the movie first? There have been a lot of movies that have come

out this year that are based off of books: “The Tale of Peter Rabbit,” “The War with Grandpa,” “A Wrinkle in Time” and “Christopher Robin” just to name a few. The second “Fantastic Beasts” movie and

“Mary Poppins Returns” are coming out soon. Did you know that there are eight books in the Mary Poppins series? They were written by British



writer P.L. Travers and published over a 64-year period of time. The books center on the magical English nanny, Mary Poppins who is blown by the East wind to Number 17 Cherry Tree Lane, London, and into the Banks’ household to care for their children. Encounters with pavement-painters and shopkeepers, and various adventures ensue. P.L. Travers said, “A writer is, after all, only half his book. The other half is the reader and from the reader the writer learns.”

Early

Deseret News



CONNECT

1 2 3

Your Family • Community • World

My name: _____

Spotlight

World Kindness Day!



Celebrate World Kindness Day!

November 13 is World Kindness Day! Join people around the world on this day and commit random acts of kindness!

There are many simple ways to celebrate World Kindness Day. Read the list below. Choose one thing you could do. Draw a picture or write a sentence about the action you pick.

Be generous with your smile!

Give 10 hugs in one day!

Start a conversation with a new student or someone who looks lonely.

Smile at people who look sad.

Write a nice note to someone having a bad day.

Standards link: Social studies: Students understand the importance of individual action and character.

The Lion and the Mouse

This famous Aesop fable tells of the importance of kindness.

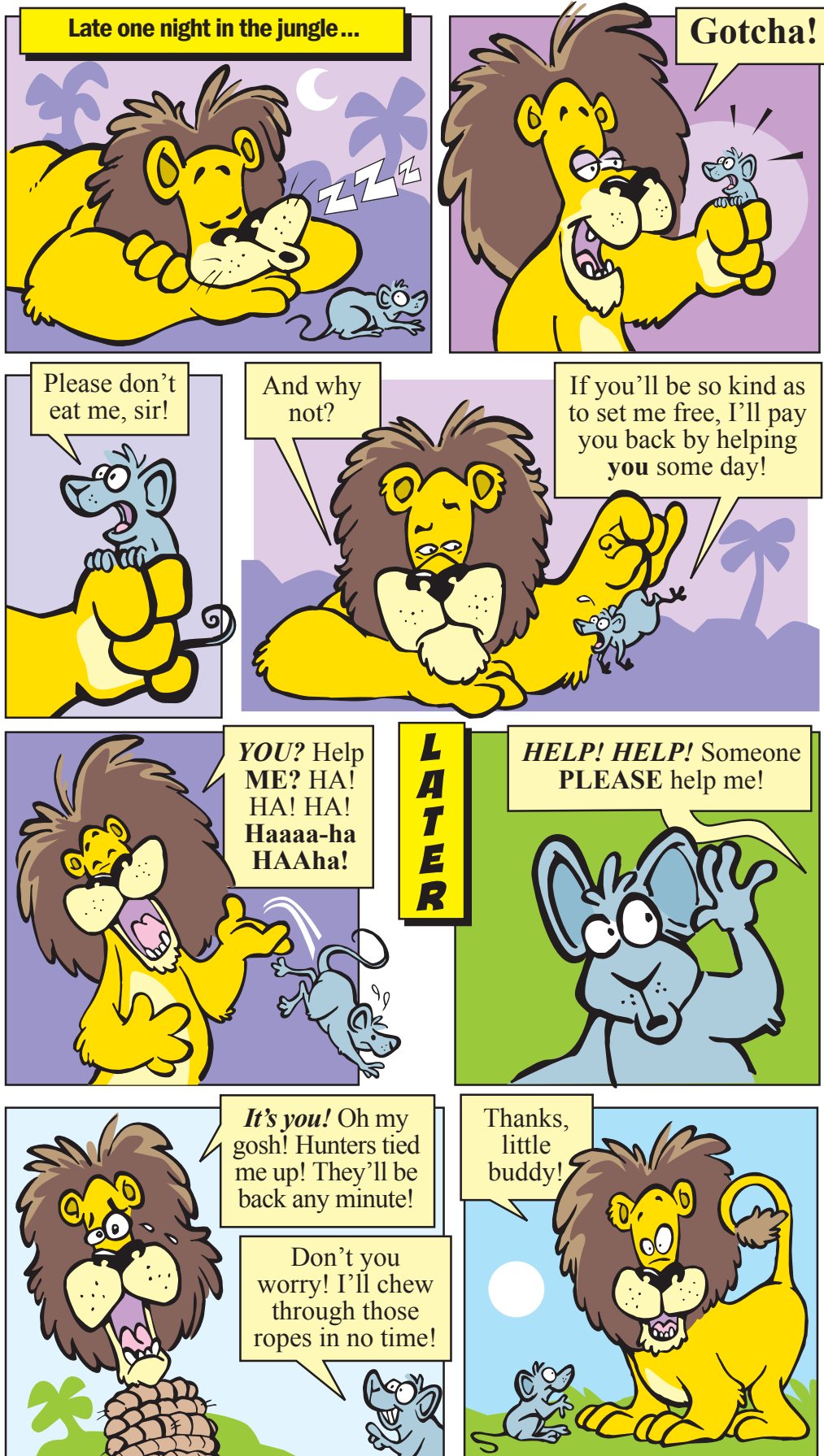

1. What unexpected acts of kindness did the lion and the mouse each do?
2. How did acts of kindness change both their lives?

Standards link: Civics: Know character traits that contribute to the health of American democracy.

Kindness news around the world

Read the news story below. Fill in the missing words on each blank line using the words in the word box.

On the Random Acts of Kindness Foundation website, you can _____ about acts of kindness being done by _____ all over the world. They have discovered that acts of kindness are not just for people, but for the _____ as well, as this story from the Philippines reveals ...

In the Philippines, we have a word for _____, it is called BAYANIHAN! When we say *bayanihan*, people of all ages come together to _____ for a common cause. On April 22, 2006, 300 young people _____ a lake clean-up along Sampaloc Lake, largest of our city's _____ lakes.

We chose the largest and most heavily _____ of the seven lakes and invited the local community to participate in the event.

POLLUTED PLANET
 CONDUCTED SEVEN
 CHILDREN LEARN
 WORK VOLUNTEERISM

You can visit the Random Acts of Kindness Foundation at www.actsofkindness.org.

Saying goodbye

Dear Connect,
I have lost my puppy.
What can I do to forget?
Sincerely,
Garrett

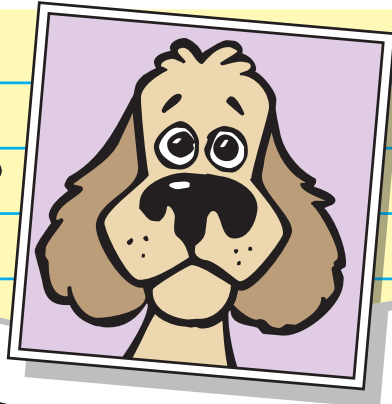

Losing a loved one is always sad. Sometimes it hurts so much that we wish we could just forget.

“Don’t forget,” says Alissa Hirshfeld-Flores of Hospice. “Remember the good things. Yes, it will hurt to remember. It’s important to cry and share your feelings with people who care about you.”

Hirshfeld-Flores knows a lot about dealing with loss. She and others at Hospice help people deal with the deaths of loved ones.

If you are feeling very sad, Hirshfeld-Flores says you should talk to an adult you trust.

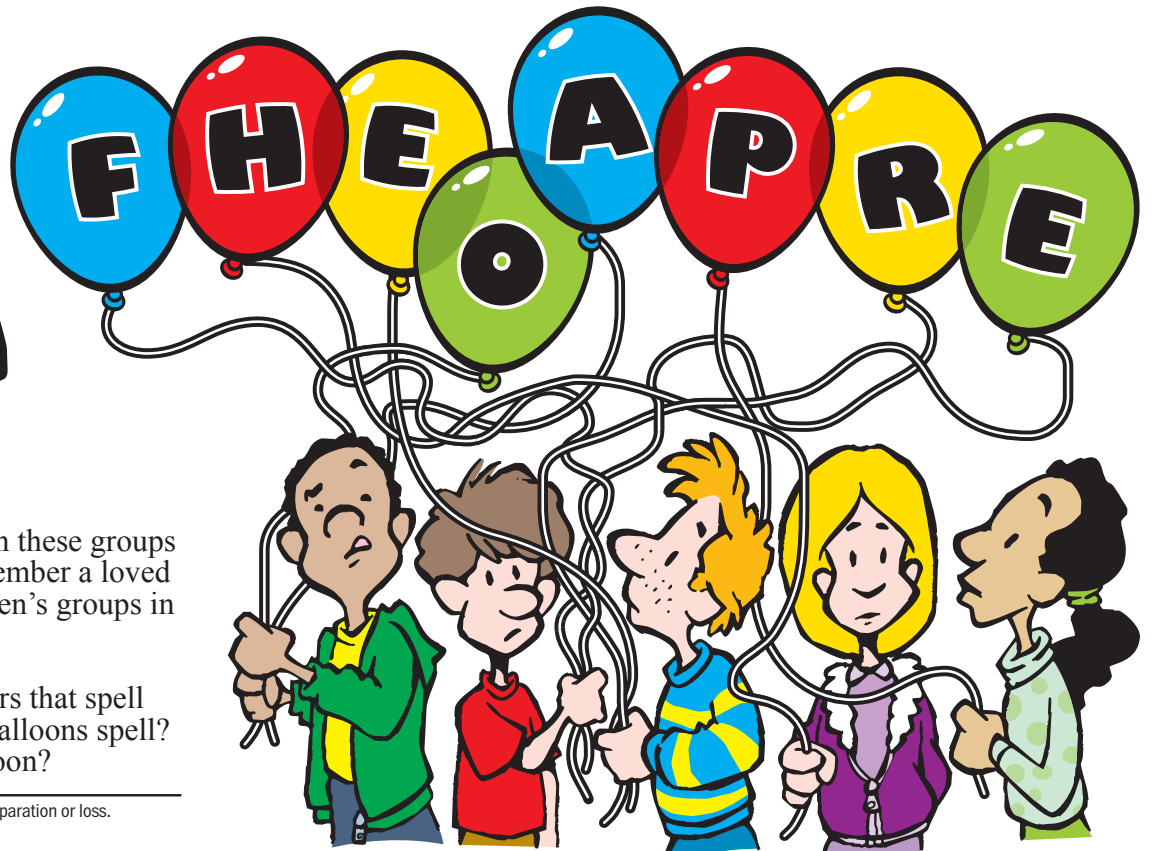

Hospice offers groups for children. Children in these groups talk about their feelings and learn how to remember a loved one in a positive way. To find out about children’s groups in your area, contact your local Hospice office.

Cross out or “POP” the balloons with the letters that spell FEAR. What do the letters on the remaining balloons spell? Can you figure out who is holding which balloon?

Standards Link: Health: Students know strategies to manage feelings caused by separation or loss.

Lasting memories

Make a “Memory Book” about someone or something you have lost. In your book, include:

- poems and stories
- pictures
- words

Think about the good memories while you make your book.

Look at this memory book page. Match the pet to its memory book.

Standards Link: Health: Students know ways to manage loss.



Special thanks to:
Alissa Hirshfeld-Flores, MFT
Bereavement Services Manager
Hospice By The Bay
(415) 526-5549

Missing vowels

The vowels are missing from this famous quote about kindness. Can you replace them all?

A = ☺ E = ☆ I = 🌸 O = ♥ U = ☾

“H_m_n k_ndn_ss h_s n_v_r w_k_n_d
 th_st_m_n_r s_ft_n_d th_f_b_r_f
 fr_p_pl. A n_t_n_d_s n_th_v
 t_b_cr_l t_b_t_gh.”

—Franklin D. Roosevelt
 32nd President of the United States

Standards link: Reading comprehension: Follow simple written directions.

Say thank you

Your parents are always reminding you to say it. Now you can amaze them by saying **Thank you** in seven different languages!

Match the **Thank you** to the country from which it comes.

-  Tak (takg)
-  Gracias (gra-see-us)
-  Merci (mehr-see)
-  Kiitos (kee-toas)
-  Danke (dahn-kah)
-  Arigato (ahree-gah-tow)
-  Dziekuje (dsyne-koo-yeh)

- FRANCE
- DENMARK
- JAPAN
- POLAND
- FINLAND
- MEXICO
- GERMANY

Standards link: Reading comprehension: Follow simple, written directions.

Light a candle

For centuries, in almost every part of the world, lighting candles has been a way to remember loved ones.

Garrett wants to burn a candle for three hours each night for one week to remember his dog Shep. Each candle is labeled with the number of minutes it will burn. Does he have enough candlelight for one week?

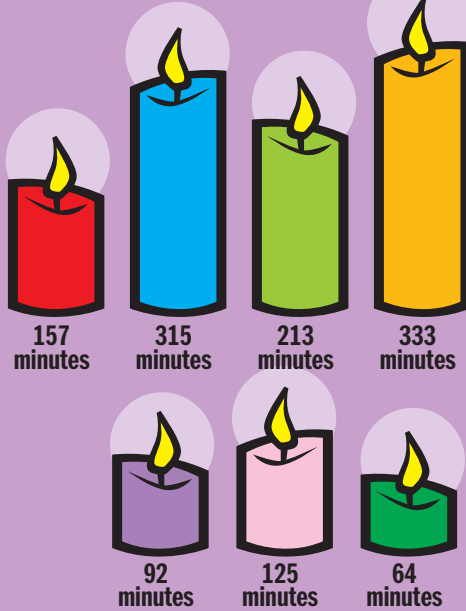

Standards link: Math/number sense: Use addition, subtraction, multiplication or division to solve problems.

ANSWERS

“Human kindness has never weakened the stamina or softened the fiber of a free people. A nation does not have to be cruel to be tough.”

Kindness news around the world
 On the Random Acts of Kindness Foundation website, you can **LEARN** about acts of kindness being done by **CHILDREN** all over the world. They have discovered that acts of kindness are not just for people, but for the **PLANET** as well, as this story from the Philippines reveals ...
 In the Philippines, we have a word for **VOLUNTEERISM**, it is called BAYANIHAN! When we say together to **WORK** for a common cause. On April 22, 2006, 300 young people **CONDUCTED** a lake clean-up along Sampaloc Lake, largest of our city's **SEVEN** lakes. We chose the largest and most heavily **POLLUTED** of the seven lakes and invited the local community to participate in the event.

CHECK IT OUT



This month's recommendations by the staff of the Salt Lake City Public Library are all about being thankful for the family and friends in our lives.



“A Dog Named Haku: a holiday story from Nepal,” by Margarita Engle. It's the Festival of Lights in Nepal, and today is the day to honor dogs!

“Thank you, Thanksgiving,” by David Milgrim. In this Thanksgiving story, a little girl goes on a last-minute errand for her mother. Along the way, she thanks all the familiar things she loves.

“The Day You Begin,” by Jacqueline Woodson. A poignant, yet heartening book about finding courage to connect, even when you feel scared and alone.

“In Plain Sight,” by Richard Jackson. Generations connect in this sweet, playful picture book.

“Gracias/Thanks,” by Pat Mora. A young boy (biracial Mexican/Caucasian) tells about some of the everyday things for which he is thankful.

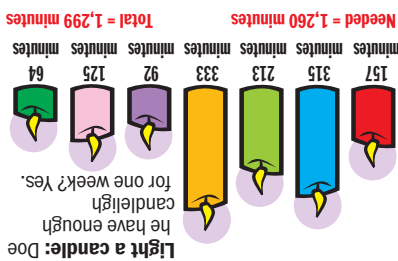

-  Dziekuje (dsyne-koo-yeh)
-  Arigato (ahree-gah-tow)
-  Danke (dahn-kah)
-  Kiitos (kee-toas)
-  Merci (mehr-see)
-  Gracias (gra-see-us)
-  Tak (takg)

Learning buddy sign here

I have completed _____ activities with my learning buddy.

Learning buddy's signature _____ Date _____

Please send ideas, suggestions or information to: nie@deseretnews.com

If you would like to receive FREE copies of Connect 1•2•3 for your classroom, order on the Web at deseretnews.com/nie. Connect 1•2•3 is a FREE monthly educational section available only to schools through the Deseret News.

Content created for the Deseret News by: Kid Scoop. Educational fun for kids ages 4-11. www.kidscoop.com

NIE director: Cindy Richards crichards@deseretnews.com
 55 N. 300 West
 Salt Lake City, UT 84101
 801-237-2172



Early

Deseret News



CONNECT 1 2 3



Your Family • Community • World

My name: _____

Government

Find at least 10 differences between the two pictures.



Party time

Have you been seeing elephants and donkeys everywhere? These are the symbols for the two biggest political parties, Republicans and Democrats.

The elephant is the Republican symbol. Twenty years after the Republican Party formed, a cartoonist used an elephant to symbolize the party, as it had become the biggest political group in the U.S.

The donkey is the symbol for the Democratic Party. In 1828 Andrew Jackson started the Democratic Party when he was running for president. The people who did not want Jackson for president called him names. They said he was as foolish as a donkey. Instead of getting mad, he turned the donkey into his symbol and won the election!

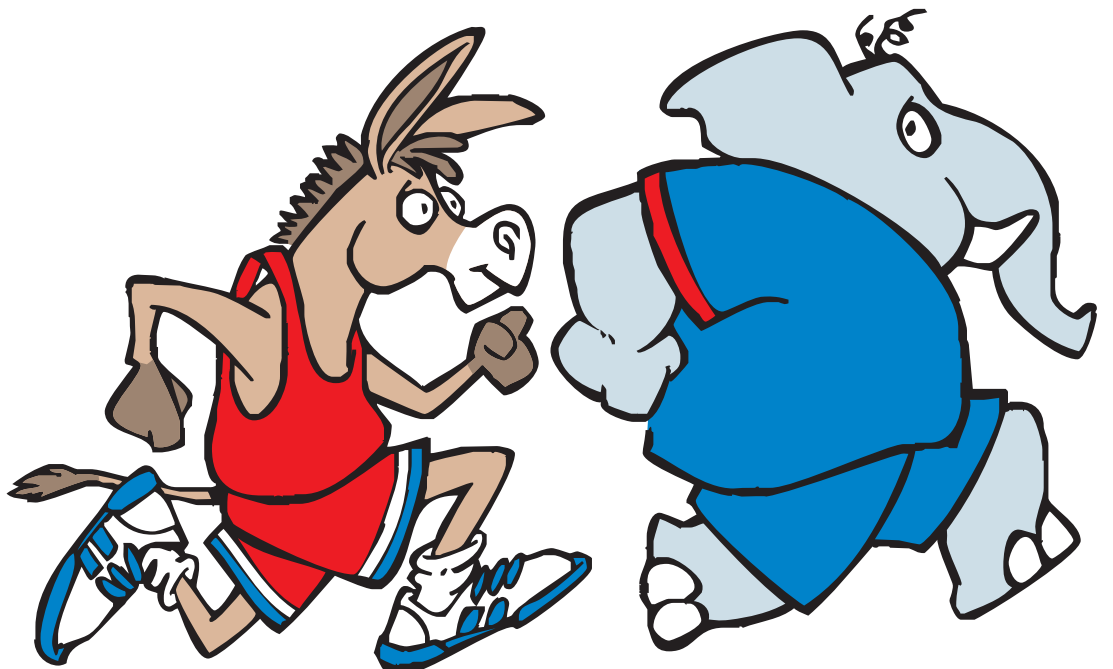



On your marks, get set, **go!** The race has begun. But wait! These racers are giving speeches and shaking hands. Why aren't they running?

They *are* running – running for office, that is.

This fall, Americans 18 years old and older will vote for people to fill elected jobs such as governors, senators, representatives, city council members, school board members and more.

Look through your newspaper to find the names of people running for offices. Cut out their names and the names of the offices they hope to win. Who else is trying to get elected to these offices?

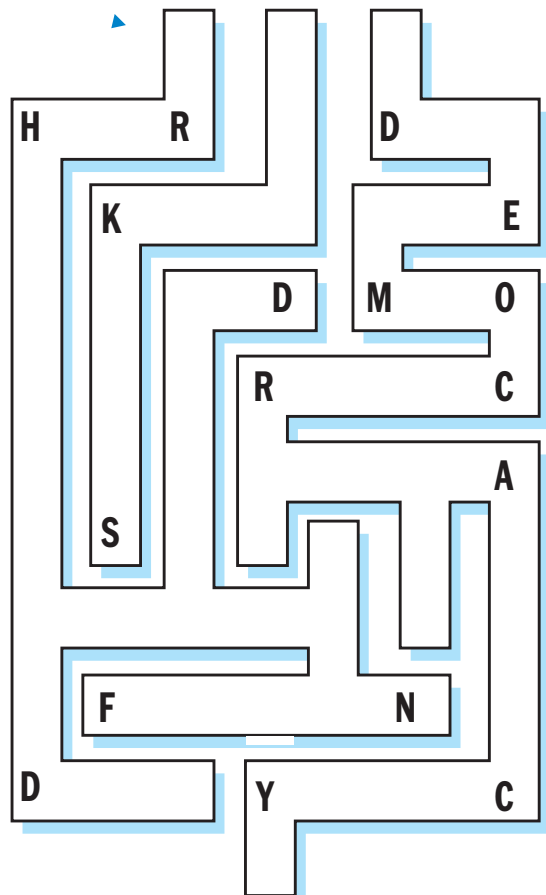

The right to vote makes our form of government in the United States a

To find the word that goes in the blank, write down each letter you pass along the correct path of the maze.

ELECTION 2018		
CANDIDATE Name of the person running for office	OFFICE Which job do they want?	PARTY Republican, Democrat, Reform, etc.

Standards link: Reading Comprehension: Follow simple directions.

Standards link: History/Social Science: Students understand the institutions and practices of government within the United States.

Fake plants vs. real plants

Student **Jaiden Krishnan**, 4th grade, takes a scientific look at photosynthesis and its effect on the air.

QUESTION:

Can living trees/plants provide enough oxygen to really notice?

BACKGROUND

When I was 5 or 6 years old, I read the book "The Lorax" by Dr. Seuss. The story was about what happened to the world when a man came to town and chopped down all the trees. The air got gassy and nasty, all the animals got sick and left... It was no place to live. That's what the little man, "the Lorax" said.

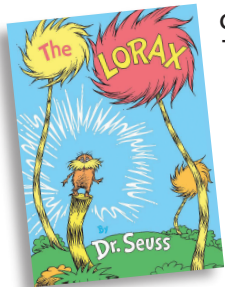

The same thing was happening in real life ... as trees get chopped down.

Air quality goes down. Life quality goes down. The Lorax was right!

In China and India, they are chopping down many of the trees to build roads and houses and buildings.

As a result, people need to go to oxygen stations to get enough oxygen to breathe.

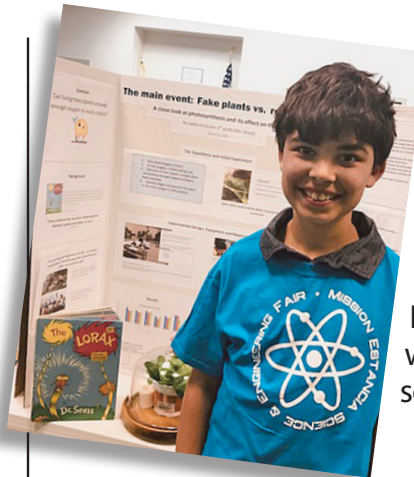

MOTIVATION

I wondered why the air was so bad, with all the gas and pollution, when people chopped down the trees.

I learned about something called **photosynthesis**. Photosynthesis is a process where plants take in water and carbon dioxide and make sugar for themselves and produce oxygen for people to breathe.

EXPERIMENT & OBSERVATIONS

Place a fresh leaf in a cup of water. Bubbles form in a water glass on the leaf. Oxygen being produced! What effect could a whole plant, or group of plants, have on the air?

- Fire needs oxygen to burn.
- In low oxygen, a flame will go out.
- Even in low oxygen, a single plant can produce enough oxygen to keep a flame burning.
- The bigger and greener the plant is, the more oxygen it will produce.

Jaiden Krishnan, age 10, lives in Walnut Creek, Calif. His hobbies are guitar, basketball, playing with his dog, listening to music, and playing "ROBLOX".

METHODS

Place candle with nothing, fake plant or real plant in the jar. If a plant is included, spray plant with water.

Light a tea candle under the bell jar and seal with Vaseline.

Using a stop watch, determine how long the candle stays lit. It requires a precise measurement.

Three conditions tested:

- No plant
- Fake plant
- Real plant

"Unless someone like you cares a whole lot, nothing is going to get better. It's not."

— *The Lorax*, Dr. Seuss, 1972



CONCLUSIONS

I proved the hypothesis: real plants produce oxygen that can make a difference (the Lorax was right!).

Plants with most leaf area produce more oxygen. Analysis shows that different plants produce different amounts of oxygen.

Most plants produce oxygen in full sun light, but some plants do not release oxygen in sunlight, for example Aloe Vera.

Some plants produce oxygen in shade.

Soil moisture is important for oxygen production and release.

LESSONS LEARNED

In our early trials, I did not seal the jar with Vaseline. I noticed the flame went from red to blue then back to red, showing that oxygen was leaking into our system. In further trials, I started sealing the jar with Vaseline.

I noticed moisture inside the jar, so after each experiment, I cleaned the jar

to ensure it wasn't blocking the light.

For each new experiment, I had to use a new candle because the amount of melted wax changed the length of time the candle would burn.

I would suggest expanding this study with many more



plants to understand which plants will be useful for creating healthy indoor air.

Full Experimental Results ■ no plant ■ fake plant ■ real plant

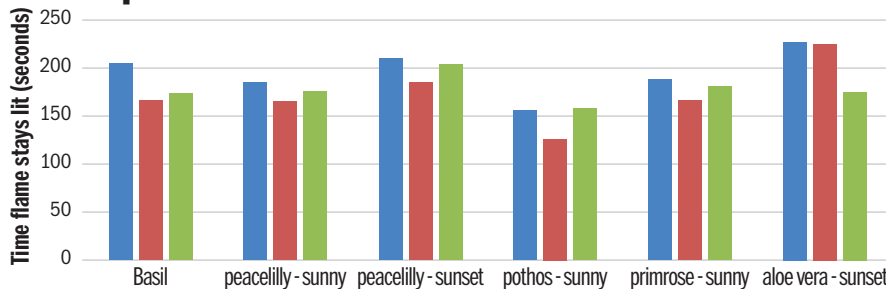

Early learners

Yellow patterns

In each row, circle the yellow fruit that should come next to continue the pattern.



Answers

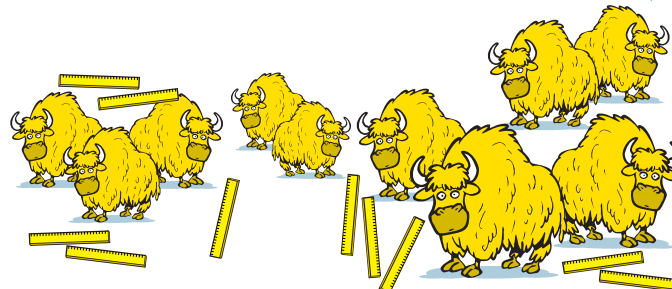
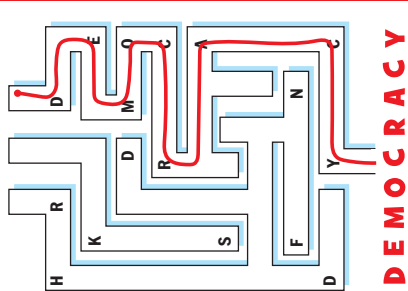

My letters

Y is for Yellow
y is for yellow

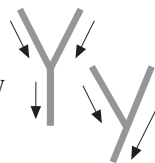

How many words or pictures can you find on this page that have the sound that the letter Y makes in the word yellow?

Learning buddies: Read the two phrases aloud. Have your child read with you. Trace the uppercase and lowercase letter Y. Say the letter as you trace it.

My rhyme time

A tisket, a tasket,
A green and yellow basket;
I wrote a letter to my love
and on the way I dropped it.

My numbers



How many yaks ?

How many yardsticks ?

Learning buddies: Trace and say the number. Read the questions. Touch and count to find the answers.

Learning buddy sign here

I have completed _____ activities with my learning buddy.

Learning buddy's signature _____ Date _____

Please send ideas, suggestions or information to: nie@deseretnews.com

If you would like to receive FREE copies of Connect 1•2•3 for your classroom, order on the Web at deseretnews.com/nie. Connect 1•2•3 is a FREE monthly educational section available only to schools through the Deseret News.

Content created for the Deseret News by: Kid Scoop. Educational fun for kids ages 4-11. www.kidscoop.com

NIE director: Cindy Richards crichards@deseretnews.com
55 N. 300 West Salt Lake City, UT 84101 801-237-2172

Read Today

POWERED BY
Deseret News

U • T • A • H



What is your favorite subject in school? Do you enjoy working with computers or building things?

If you enjoy science, technology, engineering or math there is a really fun event called STEM Fest. This year it was held at the Mountain America Expo Center on October 23rd and 24th. Read Today paired up with KSL and Deseret News to go to this fun educational event. Buses of kids from all over came to attend this event. Between all the students that came during the day and the families that came in the evening, there were about 30,000 people that attended this event.

The building was full of hands-on exhibits. Read Today has a teleprompter you could read from. It was great practice for all our future news anchors. KSL had a fun weather station. The hands-on experiences with science and technology was a great way to spark your imagination and give you a peek into future career opportunities. It was wonderful that so many students were able to join us for a fun day of hands-on learning.